

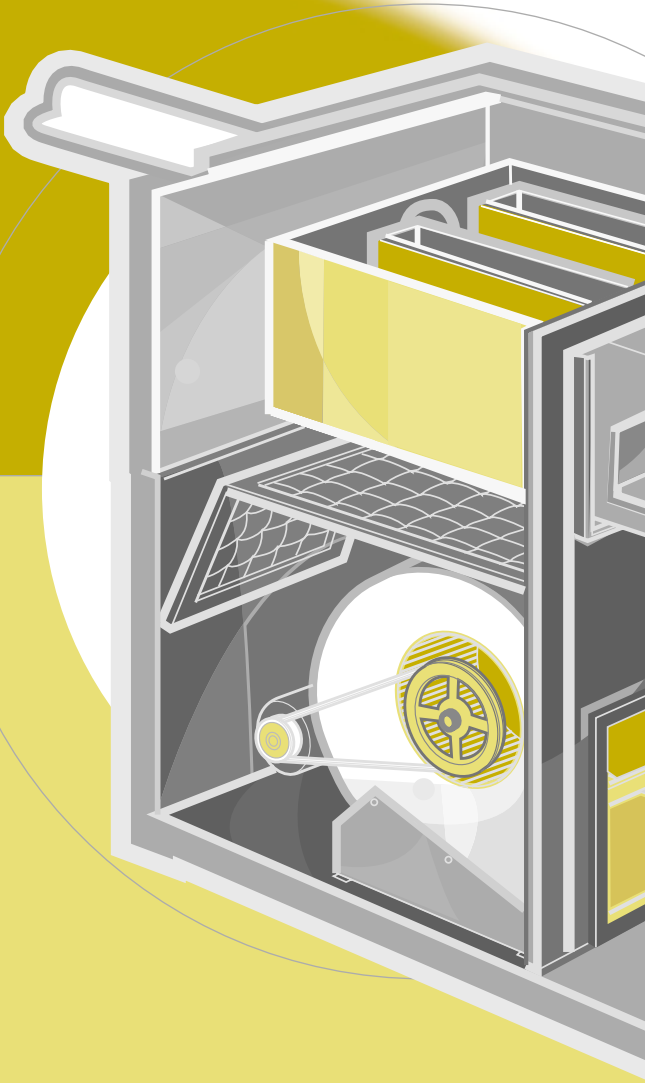

# Heating with Oil





## **Heating with Oil**

Produced by Natural Resources Canada's  
Office of Energy Efficiency

### **EnerGuide**

The Heating and Cooling series is published by Natural Resources Canada's Office of Energy Efficiency. EnerGuide is the official Government of Canada mark associated with the labelling and rating of the energy consumption or energy efficiency of household appliances, heating and ventilation equipment, air conditioners, houses and vehicles.

EnerGuide also helps manufacturers and dealers promote energy-efficient equipment and provides consumers with the information they need to choose energy-efficient residential equipment.

## Heating with Oil

Rev. ed.

### Canadian Cataloguing in Publication Data

The National Library of Congress has catalogued this publication as follows:

Heating with Oil

(Home Heating and Cooling Series)

Issued also in French under the title: Le chauffage au mazout

ISBN 0-662-35079-0

Cat. No. M91-23/4-2004E

1. Oil-burners – Handbooks, manuals, etc.
2. Dwellings – Heating and ventilation – Handbooks, manuals, etc.
3. Dwellings – Energy conservation.
  - I. Canada. Natural Resources Canada
  - II. Canada Centre for Mineral and Energy Technology

TH7403.H5214 1996 697.044 C95.980002-6

© Her Majesty the Queen in Right of Canada, 2004

Reprinted January 2004

*Aussi disponible en français sous le titre :*

Le chauffage au mazout

To receive additional copies of this publication, write to:

Energy Publications  
Office of Energy Efficiency  
Natural Resources Canada  
c/o S.J.D.S.  
Ottawa ON K1G 6S3  
Tel.: 1 800 387-2000 (toll-free)  
Fax: (819) 779-2833  
In the National Capital Region, call 995-2943

You can also view or order several of the Office of Energy Efficiency's publications on-line.

Visit our Energy Publications Virtual Library at

**[oe.e.nrcan.gc.ca/infosource](http://oe.e.nrcan.gc.ca/infosource)**.

The Office of Energy Efficiency's Web site is at **[oe.e.nrcan.gc.ca](http://oe.e.nrcan.gc.ca)**.



Recycled paper



# Contents

<b>Introduction</b> .....	2
<b>Chapter 1</b> The Four-Step Decision-Making Process for Home Heating .....	6
<b>Chapter 2</b> Basic Heating Equipment for Oil-Fired Systems .....	17
<b>Chapter 3</b> The New High-Efficiency Furnaces ....	33
<b>Chapter 4</b> Comparing Annual Heating Costs ....	38
<b>Chapter 5</b> The Mechanics of Buying, Installing or Upgrading a System .....	44
<b>Chapter 6</b> Maintenance .....	48
<b>Chapter 7</b> Domestic Water Heaters .....	54
<b>Chapter 8</b> Need More Information? .....	58

## INTRODUCTION

If your present home heating system is costing too much to operate, is in poor condition, or if you are planning to buy a new home, you are probably considering your heating options. About 60 percent of the energy required to run the average home is used for space heating. One of the most important projects you will undertake as a homeowner, along with insulating and air sealing, is choosing, changing or modifying your heating system. A wise decision about heating can significantly reduce the cost of running your home and make it more comfortable. Some impressive improvements have been made in heating systems in recent years, and there is a wide range of good equipment on the market.

You will be using your new or improved heating system for a long time, so it's important to do your homework before you make a choice. It's worth taking the time now to ensure that you make the best choice for your situation. You should thoroughly investigate all your options first. These days, however, your options may be quite bewildering because of the wide range of equipment and energy sources available. This booklet will help you in your decision-making process. It will be useful whether you are installing a system in a new home, replacing a system in an existing home or simply considering upgrading your present system.

### **How to Use this Booklet**

To simplify the process of choosing a heating system, we have identified four interrelated steps for making your home-heating decisions:

**Step 1:** Draftproofing and insulating

**Step 2:** Selecting your energy source

**Step 3:** Selecting or improving your heat distribution system

**Step 4:** Selecting your heating equipment

These steps and various options are discussed briefly in Chapter 1. The remainder of this booklet focuses on the **oil heating** option. If you decide to use **gas, electricity, wood** or a **heat pump** to heat your home, refer to the companion booklets in this series entitled:

- *Heating with Gas*
- *Heating with Electricity*
- *A Guide to Residential Wood Heating*
- *Heating and Cooling with a Heat Pump*
- *All About Wood Fireplaces*
- *All About Gas Fireplaces*

These booklets are available from Natural Resources Canada (NRCan) or from your local oil or gas dealer or electrical utility. Refer to page 58 for information on how to order them.

How you use this booklet is determined in part by where you are in your decision-making process:

- If a new house is being built for you, you may have all the steps and options open to you (Steps 1 through 4).
- If you already own your home but are considering replacing an existing heating system, many of the steps and options may be available if you have a variety of fuel/energy choices in your area (Steps 1 through 4).
- If you already have a satisfactory heat distribution system, either forced-air or hydronic, and are interested only in upgrading it (Step 3) and reducing your heating bill, then your options are switching energy sources (Step 2), selecting higher efficiency equipment, or upgrading and adding equipment to your current furnace or boiler (Step 4). You may also decide to insulate and draftproof (caulk and weatherstrip) your house (Step 1).
- Even if you are satisfied with your existing heat source, you should still look at Steps 1, 3 and 4.

Before proceeding any further, you should familiarize yourself with a number of basic concepts that will help you understand your options.

## Heating Concepts

### **Energy efficiency**

All fuel-burning systems (oil, natural gas, propane, wood) lose heat because of transient operation, cold start-up, incomplete combustion, heat carried away in combustion gases and warm house air drawn up the chimney. The extent of these losses determines the efficiency of the furnace or boiler, given as a percentage indicating the amount of original heat that actually warms the house.

**Steady-state efficiency** measures the maximum efficiency the furnace achieves after it has been running long enough to reach its peak-level operating temperature. This is an important standardized testing procedure that is used by a serviceworker to adjust the furnace, but the figure it gives is not the efficiency the furnace or boiler will achieve in actual use over the course of a heating season. This is much like the difference between the fuel consumption figures published for cars and the actual consumption of the car in day-to-day service.

**Seasonal efficiency** takes into consideration not only normal operating losses, but also the fact that most furnaces rarely run long enough to reach their steady-state efficiency temperature, particularly during milder weather at the beginning and end of the heating season. This figure, better known as the **Annual Fuel Utilization Efficiency (AFUE)**, is most useful to a homeowner because it provides a good indication of how much annual heating costs will be reduced by improving existing equipment or by replacing it with a higher efficiency unit (see “Typical Heating System Efficiencies and Energy Savings” Table 1, page 39).

If you are heating with oil or are considering doing so, the more you understand the terminology associated with oil-heating systems, the better equipped you will be to make a wise heating system choice. The text box “Oil Heating Terms” presents some of the basics.

## Oil Heating Terms

### Fuel oil

Several grades of fuel oil are produced by the petroleum industry, but only one is commonly used for most home heating. This is Number 2 fuel oil, and it must meet government and industry standards for density, viscosity, sulphur content and heat content.

### Measuring up

The heating (bonnet) capacity of oil-heating appliances is the steady-state heat output of the furnace, measured in **British thermal units per hour (Btu/h)**. One Btu is equal to the amount of energy it takes to raise the temperature of one pound of water by one degree Fahrenheit. Most oil-fired central heating appliances being sold for home use today have heating capacities of between 56 000 and 150 000 Btu/h. One litre of Number 2 fuel oil contains about 38.2 megajoules (36 500 Btu) of potential heat energy. Heating capacity is also expressed in **megajoules per hour (MJ/h)**.

The heating capacity of electric heating systems is usually expressed in **kilowatts (kW)**. A **kilowatt hour (kWh)** is the amount of electrical energy supplied by 1 kW of power over a one-hour period.

### Certification and standards

All fuel-burning furnaces, boilers and other combustion equipment sold in Canada must meet strict manufacturing and installation standards established by such organizations as the Canadian Standards Association (CSA), the Underwriters' Laboratories of Canada (ULC), the Canadian Gas Association (CGA) and the International Approval Services (IAS). These independent bodies set standards and test for safety and performance. Before purchasing your heating equipment, be sure it carries a CSA, ULC, CGA, IAS or Warnock Hersey certification label. Since January 1979, an oil furnace or boiler must record a steady-state efficiency of at least 80 percent to receive certification.

In some provinces/territories and federally, energy efficiency standards are now or will soon be in place. These require oil furnaces to achieve at least 78 percent AFUE and oil boilers at least 80 percent AFUE (see page 15 for further information on energy efficiency standards).

No matter how you are heating your home at the moment, you can probably improve the efficiency of your heating system. Some of the improvements are simple enough that you may be able to do them yourself; others require changes that can be performed only by licensed servicepersons, qualified heating contractors or electricians (in the case of electric systems). All improvements should be effective and pay for themselves in a reasonable time. When you are thinking about your heating system, remember to also consider your **hot water** situation.

## 1. THE FOUR-STEP DECISION-MAKING PROCESS FOR HOME HEATING

In this chapter, each of the four steps in the decision-making process for home heating are described in detail.

### Step 1: Draftproofing and Insulating

It is counter-productive to invest in a new or improved heating system only to allow much of its heat to escape because of an inefficient house envelope that needs more insulation or has many air leaks. To avoid this, take a closer look at where you can draftproof and insulate simply and effectively **before** having your heating system sized, installed or upgraded.

There are many advantages to draftproofing and insulating. Heating the house will cost considerably less, and you will be more comfortable because of fewer drafts and warmer surfaces, such as walls. Your house will tend to be cooler in the summer too. Another benefit to draftproofing and insulating relates to humidity levels. Dry air in a house during the winter is caused by too much outside air getting in. Although the relative humidity may be high for cold outside air, the absolute amount of moisture (water vapour) this cold air can hold is actually very low. When this air is brought inside and heated to house temperature, it becomes extremely dry.

If the air inside your house feels too dry, one of the simplest solutions is to add moisture, using a humidifier or an evaporator tray. However, the best way to increase humidity levels (and lower heating costs) is to reduce air leakage. In general, most houses that have been tightened do not need a humidifier – the moisture generated through cooking, bathing, dishwashing and other activities is more than adequate.

However, with an airtight house the reverse can occur. Making your house more airtight can affect the air quality inside. Unwanted fumes, odours, gases and too much humidity can be trapped **inside** the house envelope and build up over time to unpleasant levels. One of the best ways to solve this problem is to install a fresh air intake or a mechanical ventilation system that brings in and circulates fresh air without causing drafts. Your serviceperson should be able to provide you with more information.

Insulating, caulking and weatherstripping will reduce the amount of heat needed to keep your house comfortable. If your existing home has not been thoroughly reinsulated and draftproofed, you should consider doing this **before** changing or modifying the heating system. For more information about draftproofing and insulating, write for a free copy of *Keeping the Heat In* (see page 58). Whether you plan to do it yourself or hire a contractor, this publication explains the details (including proper insulation levels) and can help make the whole job easier.

To ensure that you get a heating system with the right heating capacity, be sure to draftproof and insulate **before** you and your contractor determine what size of heating system and equipment is best. In general, oversized furnaces will waste fuel because they tend to operate in frequent, short cycles. They may also decrease comfort because of the resulting excessive temperature fluctuations.

If you are buying or building a new house, insist on the R-2000 Standard. R-2000 homes have high levels of insulation, airtight construction, heat recovery ventilators, energy-efficient windows and doors, efficient heating systems and other design features that cut heating

requirements by as much as 50 percent compared with conventional construction. The house is more comfortable to live in, and a high-quality product is ensured. For more information on R-2000 homes, contact NRCan (see p. 59) or your provincial/territorial home builders' association.

## **Step 2: Selecting Your Energy Source**

The next step is to select the heating energy source that is right for you. Generally, your options include oil, natural gas, propane, electricity or wood. You may also choose a combination of these conventional energy sources or alternatives, such as solar energy. Your decision regarding the most appropriate energy source should be based on a number of considerations, the most important of which are described below.

### **ENERGY AVAILABILITY**

Not all energy sources are available in all areas of Canada. Heating oil and electricity are generally available in most places, but natural gas, which must be delivered by pipeline, is not available in much of the Atlantic region or in many rural and remote areas of other provinces. Propane is available in most parts of Canada and may be used in rural or cottage areas as a substitute for fuel oil or natural gas, although often at a significantly higher operating cost. In many areas, wood is a cost-effective complement to your conventional heating system. Check with your local fuel supplier or electrical utility to find out which energy sources are available in your area.

### **COST CONSIDERATIONS**

For most homeowners, the major factor in the home-heating decision is cost. This factor will have two major components – the capital cost of the installed heating system and the annual operating cost for energy. Other factors, such as maintenance costs, cleanliness and noise of operation, should also be considered.

**Installation costs** of various heating systems, depending on whether they are new or retrofitted, include such items as:

- hookup to gas lines or electric power lines
- cost of 200-amp service for electric heating
- storage tanks for oil or propane
- heating equipment (furnace, boiler, baseboard heaters, heat pump, etc.)
- new or modified chimney or venting system (if required)
- ducting system or pipes and radiators
- thermostats and controls
- cost of trenching or drilling for earth-energy systems (ground-source heat pumps)
- labour for installation of any of the above

The capital cost of a heating system can range from as low as \$1,000 for baseboard heaters in a small house to as high as \$12,000 or more for a ground-source heat pump capable of providing heating, air conditioning and hot water for a larger home. Heating contractors or utility representatives can give you an estimate of the capital cost of various systems. Always ask for a firm quote before you authorize any work.

Because of their apparently low initial cost, electric baseboard heaters are used in the majority of electrically heated homes in Canada. Today, with much higher electricity rates, the annual cost to heat such a home has become quite high. After being installed, it is fairly difficult and costly to convert to a different energy source and heat distribution system.

The **operating or fuel cost** of a heating system is determined by the following three major factors:

1. *The annual heating load or heating requirements of the house.* This depends on climate, size and style of house, insulation levels, airtightness, amount of useful solar energy through windows, amount of heat given off by lights and appliances, thermostat setting, and other operational factors. Together, these factors determine how much heat must be supplied by the heating system

over the annual heating season. This number, usually expressed as Btu, kWh or MJ per year (see page 5 for a definition of these terms), can be estimated by a heating contractor, home builder or utility representative.

2. *Choice of energy source and its unit price.* Each energy source is measured and priced differently. Oil and propane are priced in cents per litre ( $\text{¢/L}$ ); natural gas in cents per cubic metre ( $\text{¢/m}^3$ ), dollars per megajoule ( $\text{\$/MJ}$ ) or dollars per gigajoule ( $\text{\$/GJ}$ ); electricity in cents per kilowatt hour ( $\text{¢/kWh}$ ); and wood in dollars per cord. You must consider the heat content of the various energy sources to determine the most cost-effective energy source for your area. Check with your local utility or fuel supplier for the price of energy sources. Table 2 on page 40 gives the energy content for the various energy sources in the units in which they are commonly sold.
3. *Equipment efficiency.* The seasonal efficiency with which the appliance converts the energy source to useful heat in the home is also an important factor in the heating cost equation. For example, if a furnace has an AFUE (see page 4) of 80 percent, then 80 percent of the heat value in the fuel is available. The other 20 percent is lost, mostly up the chimney; thus, additional fuel must be consumed to make up for these losses. Improving the efficiency of the heating equipment reduces energy use and cost.

The combination of heating load, fuel choice and equipment efficiency determines the annual cost of heating. A detailed description of how you can calculate heating costs for various energy sources and technologies is given in Chapter 4, along with typical seasonal efficiencies (AFUE) for a range of technologies.

In the end, a homeowner thinking about a new heating system must balance the capital cost against the operating cost and make the best financial decision, taking into consideration how energy prices might change in the future. Because annual operating costs (and the differences in operating costs with different technologies) are significant compared with capital costs, an investment in high-efficiency equipment is often the wise choice.

## ENVIRONMENT

The effects of energy production and consumption play an important role in many of today's key environmental problems. Exploration and extraction of fossil fuels in fragile ecosystems, spills and leaks during transportation, urban smog, acid rain and global climate change – all can adversely affect our environment. Each form of energy has a different impact at various points in the energy cycle. No form of energy is completely harmless, although the environmental impacts of some sources of supply, such as passive solar energy, are relatively insignificant.

Heating your home affects the environment in different ways, from gases leaving the chimney, to emissions at a coal-fired electricity generating station, to flooding at a remote hydroelectric site. The overall environmental impact is determined by the amount and type of energy source your heating system uses.

Selecting the cleanest energy source is within your power, but this is often a complex assessment that may vary among regions in Canada. The combustion of natural gas, propane or fuel oil in your furnace releases various pollutants into the local environment.

Although it is easy to blame pollution on combustion products from your fuel-fired heating system, it becomes more complex when electricity is involved. Electricity is clean at the point of use, but it has environmental impacts at the point of generation. In Alberta, Saskatchewan, New Brunswick, Nova Scotia, Prince Edward Island, Newfoundland and Labrador and Ontario, coal or heavy oil is burned to meet electricity demand during the winter. In the other provinces – Manitoba, British Columbia and Quebec – where winter peak demand is met with hydroelectric power, the environmental impact is much less obvious. However, in some instances, emissions of methane can be high in hydro dam projects. Nuclear power has its own set of environmental problems.

In short, there is no easy solution, but by buying the most efficient system with the most appropriate energy source for your area, you can make a major contribution to environmental health. And by improving energy efficiency, you

reduce greenhouse gas emissions that contribute to climate change. Other approaches that can reduce energy use as well as the impact on the environment include improving insulation and airtightness (while ensuring proper ventilation), maintaining your heating system, installing setback thermostats and improving your heat distribution system.

### **Step 3: Selecting or Improving Your Heat Distribution System**

Most heating systems today are either forced-air systems or hydronic (hot water) systems. These consist of a heating unit (furnace or boiler), a distribution system (ducts and registers, or pipes and radiators) and controls (such as thermostats) that regulate the system. Some houses use space heaters and may not have distribution networks.

#### **FORCED-AIR SYSTEMS**

By far, the most common type of central heating system used in Canadian homes is the forced-air system with a furnace as the heat source. Among its advantages are its ability to provide heat quickly and the fact that it can also be used to filter and humidify household air. It can also provide ventilation and central air conditioning. In addition, the furnace fan can be used year-round to provide continuous air circulation throughout the house while efficiently distributing heat in colder months.

Forced-air heating systems also have some disadvantages. The temperature of the air coming from the heating registers can vary depending on the type of system. The air can sometimes feel cool (especially with certain heat pumps), even when it is actually warmer than the room temperature. The effect is much the same as the cooling action of a fan or a summer breeze. In addition, there can be short bursts of very hot air, especially with oversized systems. Some people may find these characteristics uncomfortable at times. The ductwork that distributes the heat may transmit the noise of the furnace and its circulating fan to every room and may circulate dust, as well as cooking and other odours, throughout the house. Consult your heating contractor for further information.

## HYDRONIC HEATING SYSTEMS

A hydronic heating system uses a boiler to heat water, which is then circulated through the house before returning to the boiler to be reheated.

Oil-fired boilers for conventional hydronic heating systems typically produce hot water at approximately 82°C (180°F) and are part of a closed system.

Hot-water or steam-heating systems once had large boilers and used wrought-iron pipes and massive cast-iron radiators; some of these still exist in older homes. For many years now, installers have been using smaller copper piping, slim baseboard heaters, and smaller, more efficient boilers. Recently, CSA-approved plastic piping has become available as an alternative to copper piping for space heating and service hot-water distribution.

## OTHER TYPES OF SYSTEMS

Apart from the more popular systems noted above, other systems that can be used independently or in combination with the standard systems are also available. These include **room space heaters**, **radiant space heaters** and **built-in radiant systems**.

**Room space heaters** provide heat directly to the rooms in which they are located and do not have a central heat distribution system. Obvious examples are wood stoves, vented oil-fired space heaters, and electric or gas-fired baseboard heaters.

Some space heaters can also be very effective radiant heat sources, warming solid bodies, such as people, in their line of sight without necessarily having to heat up all the air. Good examples are the new direct-vent gas fireplaces, advanced combustion wood fireplaces and portable electric infrared radiant heaters. If properly located in a major living space, a **radiant space heater** can actually act as an effective surrogate zoning system, lowering the overall heat demands of the house and the final heating bills while making the occupants feel more comfortable.

**Built-in radiant systems** are generally of two types: hot water pipes in floors and electrical cables in floors, which may also be installed in ceilings. The radiant floor type, becoming increasingly popular, consists of narrow hot water pipes embedded in the floor or laid in the joist space under the floor. Hot water at a temperature of around 40°C (104°F) is pumped slowly through the pipes and radiates heat into the house. Thick carpets can reduce effectiveness significantly by acting as insulation. Such a system may be more costly to install and does not appear to offer much in direct energy savings. However, some radiant floor installations may offer comfort benefits, resulting in lower thermostat settings and reduced heating bills.

Your choice of heat distribution system may be limited if you have a forced-air or hydronic system already in place. If you have an electric baseboard heater and are faced with high heating bills, you may want to change to another type of system and energy source, even though it can be an expensive undertaking. Although a major constraint is the lack of a distribution system, many homeowners are finding that air ducts for a central forced-air system or pipes and radiators for a hydronic system can be installed at a cost that still makes the whole conversion financially attractive. Fuel-fired space heaters, wood stoves and advanced, energy-efficient wood- or gas-fired fireplaces can also be effective. Your final choice will probably be based on the answers to one or more of the following questions:

- How much will the system cost compared with other systems?
- Will this type of system suit my lifestyle? Will I be comfortable with it? Do I want central ventilation, air conditioning or air circulation?
- Is there a contractor available to install the system?
- Is the system compatible with my energy choice?

#### **Step 4: Selecting Your Heating Equipment**

After you have selected your energy source options and your heat distribution system, you can begin to consider your alternatives regarding heating equipment and efficiency levels. At some point in your evaluation, you will have to

consider whether to upgrade your existing heating equipment or to replace it entirely. A number of things can be done to improve the efficiency and general performance of an existing heating system. You also have the choice of several different replacement models with various efficiency ratings and prices.

Following are some details to consider when choosing your equipment.

### **EQUIPMENT EFFICIENCY AND SUITABILITY**

Refer to Chapters 2 and 3 for a detailed discussion of your options for oil furnaces and boilers.

### **PURCHASE, INSTALLATION, OPERATION AND MAINTENANCE COSTS**

Generally, the more efficient heating systems have a higher capital cost. This must be kept in mind when considering any changes or new equipment purchases. You will want to make sure that the reduction in energy consumption and enhanced comfort will reimburse the improvement costs within a reasonable time. More often than not, they will.

Often, the more efficient systems require much less house air and may not even need a chimney but rather can be vented out the side wall. This makes them safer and more compatible with airtight housing. Finally, high-efficiency heating equipment can be an additional marketing attribute if you want to sell your house.

### **SERVICING AND GUARANTEES**

It is also important to know the causes and frequency of servicing your system, the price of parts, cost of servicing, and details of guarantees and warranties, such as the period covered and if parts and labour are included. If you are uncertain about a particular model, ask the seller to give you the names of people who have had one installed.

### **ENERGY EFFICIENCY STANDARDS**

The Government of Canada has implemented energy efficiency standards for some heating equipment and other energy-consuming appliances and products. Various

provincial governments have introduced energy efficiency standards, and other provinces have stated their intention to follow suit. Generally, these standards establish the minimum acceptable energy efficiency for specific types of heating equipment. After the standards are in place, low-efficiency models that do not meet the standards are no longer allowed on the market in that particular jurisdiction.

### **AVAILABILITY**

Depending on where you live, you may have some difficulty finding the type of furnace, heat pump or boiler you want. This is because the manufacturers' distribution networks may not be fully developed for all models in all parts of Canada or because certain models have been discontinued due to government minimum-efficiency standards.

## 2. BASIC HEATING EQUIPMENT FOR OIL-FIRED SYSTEMS

As noted in Chapter 1, most oil-fired heating systems today are either forced-air or hydronic systems. This chapter discusses the equipment that makes up these two distinct systems.

### Equipment for Forced-Air Systems

#### DESIGN AND OPERATION

A schematic drawing of a basic oil-fired, forced-air heating system is shown in Figure 1. This system consists of a burner fed by heating oil, usually from a storage tank within the house, firing into a combustion chamber in the furnace. The combustion gases pass through the furnace where they give up heat across a heat exchanger; they are then exhausted to the outside through a flue pipe and chimney. A barometric damper, acting as a valve in the flue pipe, isolates the burner from changes in pressure at the chimney exit by pulling varying quantities of heated room air into the exhaust. A circulating fan passes cool house air from the cold air return ducts over the furnace heat exchanger, where it warms up, and then passes it into the hot air ducts, which distribute the heated air throughout the house.

Notice that there are two entirely separate air movement paths. The first, the combustion path, supplies air to the burner and follows the hot combustion gases through the heat exchanger and flue pipe to the chimney and out of the house; it also includes air drawn through the barometric damper. The other path circulates and heats the air within the house.

In many houses, the quantity of air drawn through the barometric damper is much greater than the quantity required for combustion and can represent as much as 10 to 15 percent of the total heat loss in the house. Thus, anything that reduces this airflow, without compromising the performance of the furnace, will lead to increased fuel savings and efficiency.

**Figure 1** Oil-fired forced-air furnace

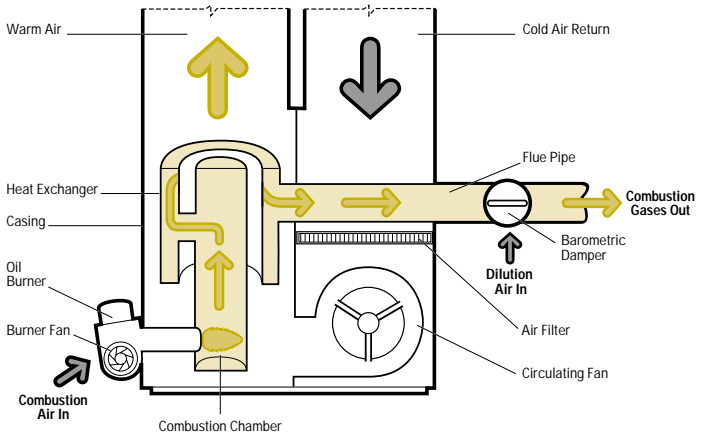

Some newer furnaces might have an optional direct connection for outside air for combustion (sealed combustion), instead of using indoor air. However, care must be taken if this approach is followed. On a cold winter's day, if the air is not warmed somewhat before it reaches the burner, it could cool the fuel oil and cause start-up problems.

A similar problem occurs when the oil is stored in a **tank outside** the house, rather than in the heated space. When the outside temperature gets very cold, the oil in the tank cools down as well. The oil can become very viscous (thick), and you may not be able to get the oil from the tank to the burner – hence, no heat. Even if it does finally get to the burner, it may be so thick that your oil burner cannot atomize it properly, and you will get poor combustion. If you have an outside tank, consider some form of heating either from the tank or the line, and install a smaller holding tank within the house to help prevent these problems. Even better, consider bringing the tank inside the house.

## Maximizing Effectiveness in Forced-Air Heating Systems

There are several ways to improve the performance of an existing forced-air heating system.

### *Adjusting the Furnace Fan*

Heat output from a forced-air system can often be increased by adjusting the controls that turn the fan on and off automatically. The fan controls are usually located in a metal box, often on the front of the furnace, near the top. Inside the box (to remove the cover, you must either squeeze it or remove some metal screws) is a temperature dial with three pointers (Figure 2) – the lowest setting is the fan OFF pointer; the next one is the fan ON setting. The third and highest pointer is the safety limit control that shuts the burner off if the furnace gets too hot. This safety limit is normally set at the factory. **Do not adjust the safety limit setting.**

**Figure 2** Circulating fan control

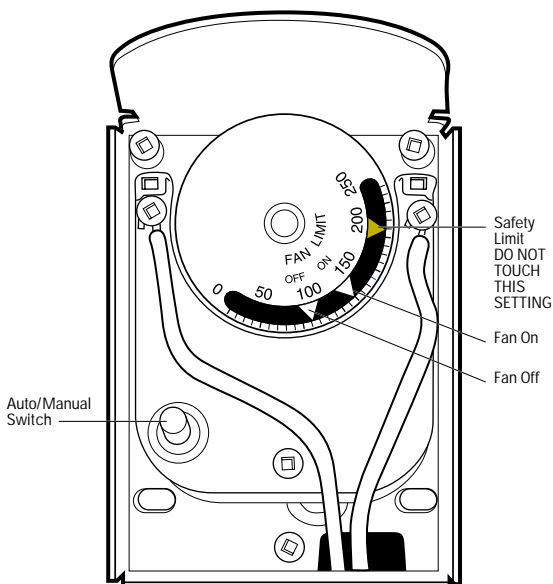

The ON/OFF fan control pointers are usually set for an ON temperature of 66°C (151°F) and an OFF temperature of 49°C (120°F). To increase the amount of heat taken from the furnace, most heating experts now recommend changing the ON temperature to 49°C (120°F) and the OFF temperature to 32°C (90°F). These changes make the fan come on sooner after the burner starts up and stay on longer after it shuts down, allowing the circulating air to extract more heat from the furnace and losing less heat up the chimney or through the vent.

The fan control dial is spring-mounted, so it must be held firmly with one hand while you adjust the pointer with the other. Make sure the “auto/manual” switch is set to “auto” after replacing the cover of the metal box. **If you feel uncomfortable or unsure of what to do to modify these settings, ask your furnace serviceperson to make the setting changes for you during the next service call.**

These changes may result in slightly lower air temperatures from the registers at the beginning and end of the furnace cycle. If the cooler air at either end of the furnace cycle makes you feel uncomfortable, try raising the fan ON setting to 54°C (129°F), the fan OFF setting to 38°C (100°F), or try both, whatever is appropriate.

A two-speed fan will allow you to get even more heat out of the furnace while providing for continuous air circulation and more even temperatures throughout the house while the furnace is off. However, this will increase your electricity bill.

Some of the new high-efficiency furnaces use a more efficient, variable-speed, direct-drive commutating motor to run the circulating fan. The speed of the fan depends on the heat demand. For extended or continuous fan operation, such a unit can save a significant amount on your electricity bill while making the delivery of heat more even and comfortable.

## ***Getting the Heat Where You Want It***

Uneven heat distribution is sometimes a problem, which results in the inability to heat some rooms in the house, such as upstairs bedrooms. This can be due to the leakage of warm air out through joints in the heating ducts or to heat loss from ductwork passing through the basement or, even worse, through unheated areas such as a crawl space, an attic or a garage. When the circulating fan is running, the house heat loss rate can significantly increase if leaky ducts are located in an exterior wall, an attic or a crawl space allowing the heated air to escape. This is one more good reason to ensure all the ducts are well sealed.

**Sealing all joints in the ductwork with a special water-based duct mastic (sealant) will reduce or eliminate warm air leaks.** Look in the Yellow Pages™ under “Furnaces – Heating” or “Furnaces – Supplies and Parts.” High-temperature duct tape may work, although it tends to degrade or permit air leakage over time.

Ducts passing through an unheated area such as a crawl space or an attic should be sealed, then wrapped with batt or **duct insulation**. Do the same for long duct runs in the basement. As a minimum, it is recommended that the warm air plenum and at least the first three metres (10 feet) of warm air ducting be insulated. Better still, insulate all the warm air ducts you can access. Use batts of insulation with foil backing, or enclose the insulated ducts in the joist space. If your basement is presently heated by the heat loss from the ducts, it may be necessary to install additional registers there after you insulate the ducts. This will ensure that the heat will be going only where you want it, when you want it, without being lost along the way.

Rooms on upper floors or far from the furnace are sometimes difficult to heat because of the heat losses described previously and also because of pressure losses from friction and other restrictions to airflow (such as right-angle bends) in the ductwork. This can sometimes be corrected by slight modifications to the ductwork after the ducts have been sealed and insulated and by balancing the dampers in the supply ducts (Figure 3) to redirect the airflow from the warmer areas to cooler rooms.

**Figure 3** Balancing damper in the supply duct

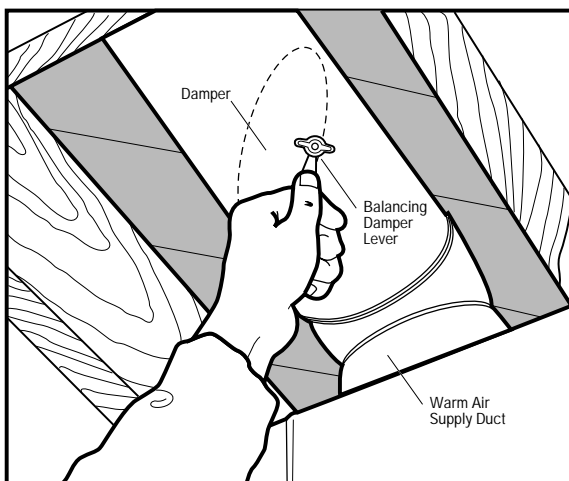

In some forced-air distribution systems, balancing dampers may be located in the secondary warm air ducts, close to where they branch off from the rectangular main heating duct. Often they can be identified by a small lever on the outside of the duct as shown in Figure 3. The position of this lever (or sometimes a slot in the end of the damper shaft) indicates the angle of the unseen damper inside the duct. If there are no such dampers, you will have to use the ones in the floor registers.

Start by closing the dampers in the ducts that supply heat to the warmest rooms (even if completely closed, they will still supply some heat to these rooms). Wait a few days to see what effect this has on the overall heat balance, then make further adjustments as necessary. Such adjustments may slightly reduce the total airflow through the furnace, but this will be balanced to some extent by a slight increase in the temperature of the delivered air.

However, you should be careful. It may be more practical to have a trained service technician do the job. If you reduce the airflow too much, you could cause an undesirable rise in the temperature inside the furnace plenum. It is a good idea to have this temperature rise checked by your furnace serviceperson.

Most houses have been designed with inadequate cold air returns, which result in not enough airflow through the furnace. Putting additional cold air returns in the living area, particularly in the bedrooms, can improve air circulation and heating system efficiency while improving comfort and air quality in the house as well.

Several years ago, it was mistakenly thought that one way to get around the problem of inadequate cold air returns was to open up the cold air return ductwork or plenum in the basement area near the furnace, or even take off the furnace access panel near the air filter. **This is dangerous.** The depressurization caused by the circulating fan can actually disrupt the combustion and result in spillage or backdrafting of combustion products. These combustion products can then be circulated around the house instead of going up the chimney. **In certain cases, this can have catastrophic results and can cause carbon monoxide poisoning.**

For stubborn heat distribution problems that cannot be corrected by damper adjustments and other duct modifications, have a qualified serviceperson do a complete and proper balancing of your distribution system.

## Automatic Setback Thermostats

The easiest way to save heating dollars is to lower the temperature setting on your house thermostat when possible. An automatic setback thermostat will adjust your home's temperature automatically. These thermostats have a mechanical or electronic timer that allows you to preset household temperatures for specific periods of the day and night. As a general rule, you will save 2 percent on your heating bill for every 1°C you turn down the thermostat overnight.

You could program the thermostat to reduce the temperature a short while before you go to bed and to raise it again before you get up in the morning. You could also program it to reduce the temperature for any period during the day when the house is unoccupied and to restore the temperature shortly before you return. A good guide is to have the

***(. . . continued)***

temperature set at 17°C (63°F) when you are sleeping or not at home and at 20°C (68°F) when you are awake and home.

Experiment with the unit until you find the most comfortable and economical routine for you and your family.

If you have a hot water (hydronic) system, you can also reduce energy use through zone control. In this system, thermostat-controlled valves on each radiator may permit the control of individual room temperatures. A plumbing and heating contractor can provide more information about zone control and can install all required equipment when the heating system is installed. Zone controls are also available for forced-air heating systems, usually with dampers in main duct passages driven by separate thermostats in different areas of the house.

### **Improved Thermostats**

More sophisticated electronic and self-tuning thermostats are also being developed. These are very sensitive and help reduce the temperature “swing” from an average range of 1.5–2°C to 0.5–1°C, ensuring that the heating system turns on and off as close to the required temperatures as possible. Energy savings from these advanced mechanisms can vary, but comfort is usually enhanced.

## **Equipment for Hydronic (Hot Water) Systems**

### **DESIGN AND OPERATION**

A hydronic heating system uses hot water to distribute the heat around the house and has the following three basic components:

- a boiler to heat the water
- heating units in most rooms, usually baseboards or radiators, which are often located on an outside wall
- a pump to circulate the water from the boiler to the radiators and back through a piping system

**Figure 4** Oil-fired boiler

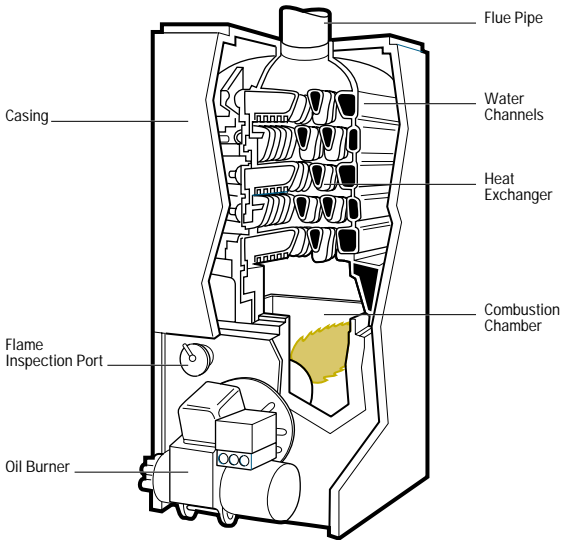

An oil-fired boiler (Figure 4) uses the same type of burner as an oil-fired, forced-air furnace, although a boiler is often somewhat smaller and heavier. There is no circulating fan and filter housing as with a forced-air system. Instead, most boilers require a circulating pump to push heat around the house through the pipes and the radiator system, as shown in Figure 5. The seasonal efficiency of old conventional hydronic systems is similar to that of conventional forced-air systems, which is around 60 percent.

**Figure 5** Hydronic heating system

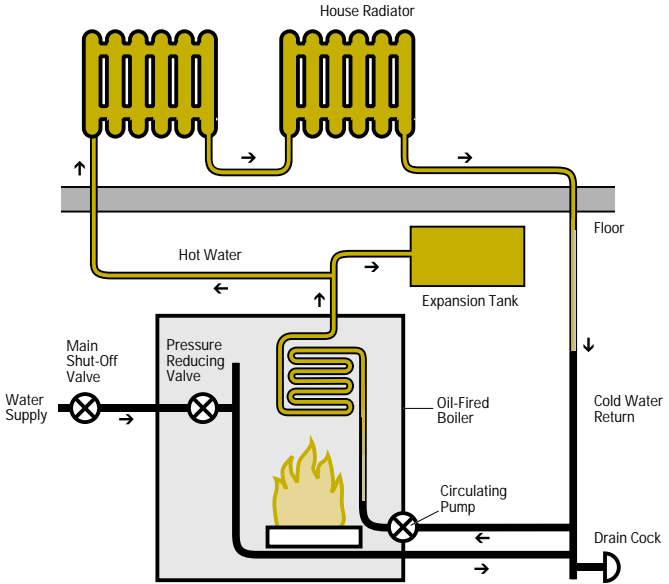

## MAXIMIZING EFFECTIVENESS

There are several ways to improve the performance of a hydronic heating system.

### *Improving Heat Distribution*

Old-fashioned gravity systems that circulate water or steam by natural convection are much less efficient than systems with a circulating pump. Slow heat circulation may cause house temperatures to fluctuate noticeably between firing cycles. It can also take a long time to restore the house temperature after a nighttime thermostat setback. In addition, a gravity system cannot circulate hot water to radiators or baseboard heaters in basement living areas, where they are below the level of the boiler. All of these problems can be overcome by adding a circulating pump and replacing the open expansion tank with a sealed and pressurized expansion tank near the boiler. If you have a gravity system, discuss the possibility of upgrading it with your plumbing and heating contractor.

## ***Balancing the Heat***

Balancing the heat delivered to different areas of the house is as important with hydronic heating as it is with a forced-air system. Radiators are often fitted with a simple manual valve that can be used to control the amount of water flowing through them. Such valves can be used to vary the heat delivered to different rooms in the same way that balancing dampers are used in a forced-air system.

One device that can vary the heat output automatically is a thermostatic radiator valve (Figure 6) that can be set to control the temperature in any room. However, this will not work on radiators or baseboard heaters installed in what is called a “series loop” system. In this particular system, the water must pass through all the radiators, one after the other, on its way back to the boiler. If there is more than one loop in the system, some balancing of the heat output can be achieved by adjusting the valves that control the water flow through each loop. The heat output of baseboard units can also be controlled to some extent by regulating the built-in damper, which operates much like the damper in a warm air register.

**Figure 6** Thermostatic radiator valve

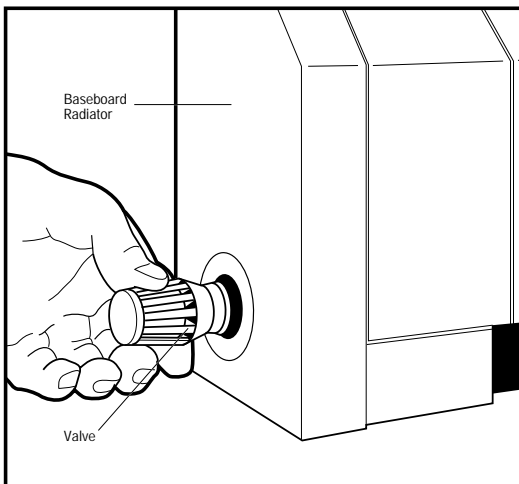

Conventional hydronic systems have the boiler water temperature set at 82°C (180°F). A device that can reduce energy consumption in many hydronic heating systems is a controller, which controls the circulating water temperature in relation to the outside air. As it gets warmer outside, the boiler water temperature is reduced. Care must be taken not to reduce the temperature too much or corrosion could result.

Homeowners can improve the efficiency of their heating systems by investing in one or more of the improvements described in this section.

## **Upgrades and Add-Ons to Basic Oil Furnaces and Boilers**

Downsizing heat output and improving combustion are two ways to upgrade your oil-fired heating system. Following are descriptions of these approaches.

### **DOWNSIZING**

Most residential oil furnaces or boilers manufactured before the late 1970s were installed with a cast-iron head burner. If your furnace or boiler still has the original burner, it has a relatively low seasonal efficiency, of about 60 percent. If you don't know what type of burner you have, ask your serviceperson.

There are four basic reasons for this low seasonal efficiency: an inefficient conventional burner, an inefficient furnace, air dilution or an oversized system.

Most heating systems in older homes are greatly oversized. Moreover, homeowners have often added insulation, caulking, and weatherstripping, and made other improvements to reduce heat loss and cut fuel consumption. As a result, the old systems are even more oversized.

We know that an automobile gets much better fuel economy when cruising on the highway than when continually starting, accelerating and decelerating in the city. Like an automobile, most oil furnaces perform best when running at their steady-state condition, with the maximum stable flue gas tempera-

ture. But the burner must for run between 7 and 20 minutes to reach this point, and some oversized units may never run long enough to get there, even on the coldest days.

Ideally, the oil burner would run continuously when the outside temperature is at the lowest temperature expected for your area, or what is called the “design temperature.” At that point, the furnace would be operating close to the steady-state efficiency for which it was rated. A running time of 45 to 50 minutes per hour at your local coldest design temperature is a practical goal. Discuss this particular concern with your serviceperson.

An oil heating system can be downsized simply by replacing the existing oil burner nozzle with a smaller sized one. Nozzles are rated in U.S. gallons per hour with typical sizes of 1.1, 1.0, 0.85, 0.75, 0.65, 0.60 and 0.50.

With conventional cast-iron head burners, you should be careful not to reduce the firing rate too much or incomplete combustion will result along with reduced furnace efficiency. If you have such a burner, you should consider reducing the nozzle only one size. In any case, with a conventional burner, the size should not be reduced below the minimum firing rate given on the manufacturer’s rating plate.

A large number of conventional oil furnaces have been retrofitted with flame-retention head burners, which has improved their seasonal efficiency. With a flame-retention head burner (see Figure 7), the nozzle size can be reduced significantly, as good combustion performance can be maintained; the lower limit on the firing rate is governed by the flue gas temperature leaving the furnace. In general, you should maintain a furnace exit temperature above 204°C (400°F) if you have an outside chimney and 177°C (350°F) if you have a chimney inside the house. The proper nozzle size for your house and heating needs can be determined by your serviceperson.

## **IMPROVING COMBUSTION SYSTEM PERFORMANCE**

There are a number of relatively straightforward things that can be done to improve combustion performance and the efficiency of an existing oil-fired furnace or boiler.

## ***Install a Flame-Retention Head Burner***

The performance of an oil-fired heating system depends to a large extent on how well air and fuel oil are mixed in the burner, a function performed by the atomizing spray nozzle that mixes air and fuel into a combustible mist.

**Figure 7** Flame-retention head burner

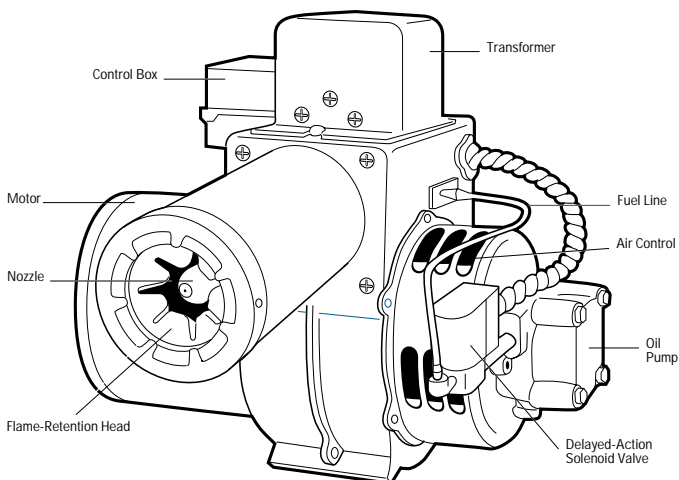

Compared with the old cast-iron head burner, flame-retention head burners do a much better job of mixing air and fuel. This reduces the amount of excess air required for good combustion. The result is a tighter, hotter flame for the same amount of fuel (see Figure 8, page 32).

A flame-retention head burner can increase the seasonal efficiency of an old oil-fired furnace (rated at an AFUE of 60 percent) by about 15 percent. Because of the increased flame temperature and higher efficiency, it is recommended that the nozzle be reduced at least one size and that a ceramic fibre combustion chamber be used.

Flame-retention heads are now almost standard on new furnaces and can also be added to most older furnaces. Contact a reputable oil service firm or fuel supplier to discuss a flame-retention head for your system.

## ***High-Static Burners***

New advanced flame-retention head burners with high-static pressure can run at even lower excess air levels. The increase in efficiency can be close to 20 percent. At the same time, the burner is powerful and can overcome pressure fluctuations generated at the vent termination, producing a stable flame even under adverse weather conditions. The pressure drop across the burner head also stops heated house air from flowing through the burner, combustion chamber and furnace and out the chimney during the furnace off-cycle. Finally, the high-static pressure makes the burner almost completely independent of depressurization within the house, a good quality to have in a tight home. It can also run as a sealed combustion unit. Because of its many advantages, it is recommended that any new furnace you buy be equipped with this type of burner.

## **VENTING YOUR INCREASED EFFICIENCY APPLIANCE**

If you have made changes to increase the efficiency of your existing system, either by replacing your burner with a flame-retention head or high-static burner or by replacing your furnace or boiler, you should have someone take a closer look at your chimney. If it is a masonry chimney located on the outside wall of your house, it may be too big for the amount of gases that will now be going through it. The flue gases can cool down and condense in the chimney, causing deterioration over time. The installation of a stainless steel, double-walled flue pipe from the furnace to the chimney can help. If the problem persists, consider adding a stainless steel liner to the chimney. Aside from preventing condensation problems, these changes can improve the chimney draft and the overall performance of your heating system.

## **INSTALL A DELAYED-ACTION SOLENOID VALVE**

An oil-fired heating system wastes heat if incomplete combustion causes a heavy layer of soot to form on the inside of the heat exchanger. This is reduced by the use of a flame-retention head burner, although a significant amount of soot can still be produced at the beginning and end of each firing cycle, which can also cause oil smells in the house.

Soot formation and the associated odours can be dramatically reduced and even eliminated by having a delayed-action solenoid valve installed on the burner between the oil pump and the burner nozzle (see Figure 7, page 30).

**Figure 8** Flame patterns with different burner heads

**Flame with Conventional Cast-Iron Head Burner**

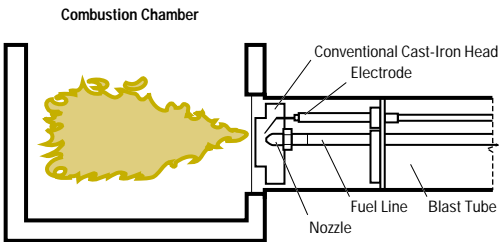

**Flame with Flame-Retention Head Burner**

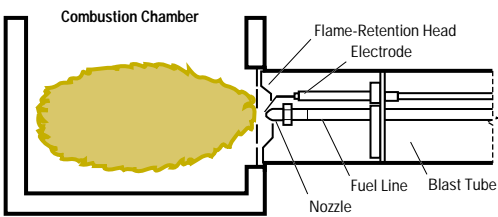

### 3. THE NEW HIGH-EFFICIENCY FURNACES

Ever since the fuel price scare of the early 1970s, the industry has been working to improve the efficiency of furnaces and boilers. The introduction of improved burners with flame-retention heads was the first major step in boosting the efficiency of conventional oil-fired heating equipment. The high-static burner, which has recently come onto the market, has further enhanced the efficiency capability of heating systems. Now manufacturers have produced a new “mid-efficiency” class of oil furnace designed to make the most of the superior performance of these new burners. Other companies have developed condensing furnaces that cool the combustion gases enough to recover the heat that is normally lost in the form of water vapour. New technologies are now allowing appliances to efficiently integrate two different functions, such as space and water heating, simultaneously.

Recently, a number of new oil-fired systems that can be vented directly out the side wall of the house, thereby eliminating the need for a chimney, have been approved in Canada.

#### **Mid-Efficiency Furnaces**

In addition to an improved high-static oil burner, a non-condensing, mid-efficiency furnace (Figure 9) features an improved low-mass combustion chamber (usually ceramic fibre) and passes the hot combustion gases through a superior heat exchanger that enables the circulating house air to extract more heat. The need for a barometric damper and the large requirement for exhaust gas dilution by house air have been eliminated in the most efficient designs.

The mid-efficiency furnace must keep the exiting gases above a certain temperature to prevent water vapour in the flue gas from condensing inside the furnace or venting system, where it can cause corrosion and other serious problems. The exit temperature of the combustion gases can be as low as 150°C (302°F).

Some of the new oil-fired equipment can be vented directly through the side wall of the house without the need for a chimney.

One sidewall-venting type uses the forced draft of a high-static burner to expel combustion gases. Others go further and use sealed combustion with a high-static burner.

Another sidewall-venting system uses an induced draft fan. This fan is normally located downstream of the furnace at the inside wall of the house and pulls the gases from the furnace out of the house through a small exhaust vent. Some of these sidewall systems require dilution air from the house or have a long run time after the burner shuts off in order to purge the furnace system of any combustion gases. Both tend to reduce efficiency.

**Figure 9** Mid-efficiency oil furnace

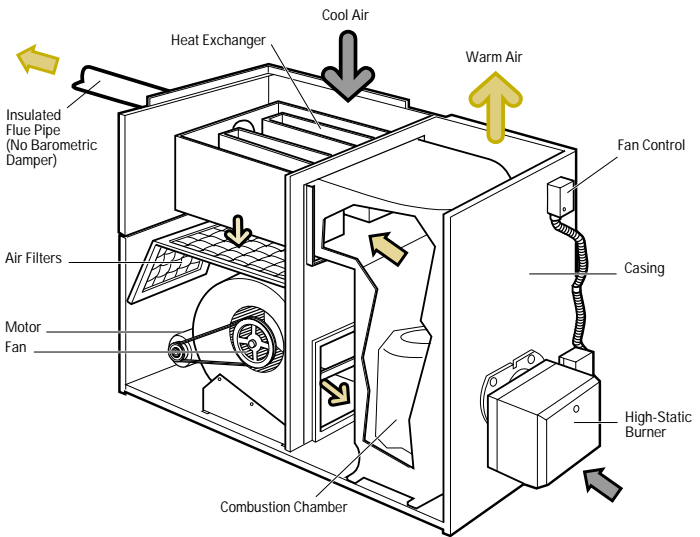

Benefits of a good mid-efficiency furnace are much lower combustion and dilution air requirements, as well as more power to exhaust the combustion products (an advantage in newer, tighter housing), a safety shut-off in case of draft problems, and a more effective venting system.

Mid-efficiency furnaces may have a seasonal efficiency of 83 to 89 percent and may use 28 to 33 percent less fuel than an old conventional furnace producing the same amount of heat.

Many heating industry experts believe that new technology furnaces, available in small enough sizes to fit the needs of even super-insulated houses, will be the next major development in oil heating. This can come about in two ways – either by developing alternative oil burner technology or by integrating the functions of different home energy requirements, such as space and water heating systems.

### **Condensing Oil Furnaces**

Heat is carried away not only in the high temperature of the flue gases, but also in the water vapour they contain. The water vapour that is produced when natural gas is burned holds a substantial amount of latent heat – about 11 percent of all the energy in the fuel. Oil, on the other hand, produces only half the water vapour of gas; thus, oil has much less energy tied up in the form of latent heat.

A condensing furnace uses an extra heat exchanger made of stainless steel to extract more heat from the combustion gases before they leave the furnace, dropping the exit temperature to between 40°C and 50°C (104°F and 122°F). This results in water vapour from the flue gas condensing inside the heat exchanger and releasing its latent heat to the house air circulating through the furnace. At this point, the combustion gases are so cool that they require only a narrow plastic vent pipe that goes out the side wall of the house, instead of up the chimney. The condensate runs to a drain outlet.

With oil containing only half the hydrogen of natural gas, the potential for efficiency improvements by condensing the flue gas is much lower for oil than for natural gas – the dew point is lower, so the furnace has to work harder to condense less. Also, with higher sulphur levels, the condensate is corrosive, so that any condensing heat exchanger for oil must be even more corrosion-resistant. The fact that oil combustion also produces a certain amount of soot,

which can concentrate the acidic condensate as “acid smut” at certain points on the heat exchange surface, makes things even more difficult. This type of furnace is only marginally more efficient than a well-designed mid-efficiency furnace.

Some condensing oil systems use two vents: the conventional chimney and a plastic pipe out the side wall of the house – both open at the same time. With this type of system, there is a strong possibility of the flue gases bypassing the water-spray condensing system and going straight up the chimney. The barometric damper is also retained, so that the additional dilution air increases the overall heat loss from the house while lowering the dew point even further; this makes it even harder to condense the flue gases. The net efficiency from such a system is less than that for a mid-efficiency furnace.

For all these reasons, a condensing oil-fired furnace is a questionable choice, at best.

## **In-House Condensation Problems**

More efficient heating systems, combined with better draft-proofing and insulation, can result in less air infiltration, which, in turn, may lead to excess moisture in the house.

Heavy condensation on the inside of windows and dampness or mould growth on walls or ceilings are indications of too much moisture. If these are not corrected, serious structural damage will eventually occur; luckily, indoor condensation problems can be solved. Because most of the indoor humidity arises from regular household activities (such as showering and cooking), your first step should be to reduce the amount of moisture from these sources. You can do this, for example, by ensuring that your clothes dryer vents to the outside, using lids on pots when cooking, and keeping showers short. You should consider installing exhaust fans in the bathroom and kitchen, vented directly to the outside. You should also check the humidifier setting on your furnace, if it is equipped with one. In fact, it may not be necessary to have a humidifier in a more airtight house. Finally, as a last resort, you should talk to a contractor about installing a heat recovery ventilator (HRV) that will increase the ventilation in your house and decrease humidity without wasting energy.

## **In-Chimney Condensation Problems**

In-chimney condensation is another possible problem. The lower flue temperature achieved by the improved efficiency of today's heating equipment has created the possibility of damage caused by flue gas condensation inside a masonry chimney, particularly one located on the outside wall where it is chilled by exposure to the outside air. Look for a white, powdery efflorescence on the outside of the chimney, spalling or flaking of the bricks, crumbling mortar joints, wet patches on inside walls behind the chimney, pieces of tile at the bottom of the chimney, and water running out of the cleanout door or around the bottom of the chimney behind the furnace. The most common cause of all of these problems is condensation inside a cold chimney. Water vapour is produced when oil or natural gas is burned, but humid house air drawn into the chimney also contributes to the problem.

Another cause of condensation is that the new, more efficient furnaces need smaller chimneys than the 200 mm x 200 mm (8 in. x 8 in.) flue tile that has been standard for many years. Because of this, the combustion gases, already cooled by the improved heat exchanger in the furnace, rise slowly in the cold, oversized flue where they are sometimes cooled to the dew point of the water vapour they contain. The resulting condensation can then leak into the bricks and cause structural or water damage. If this is caught in time, there are simple remedies. Use of a double-walled stainless steel flue pipe from the furnace to the chimney or a stainless steel chimney liner or both can usually stop this. Other solutions to these problems are described in Chapter 6.

## 4. COMPARING ANNUAL HEATING COSTS

The combination of annual heating load, energy source and equipment efficiency determines the annual cost of heating.

### Heating Costs When Upgrading Your Existing Oil Heating System

If you are presently heating with oil and are thinking of converting to a more efficient oil heating system, you may be interested in determining the savings you could expect. Table 1 (page 39) and the following formula can provide you with reasonably accurate figures. You need to know your annual fuel cost and the type of heating technology you are using.

$$\text{Annual \$ savings} = \frac{A - B}{A} \times C$$

Where A = Seasonal efficiency of proposed system

B = Seasonal efficiency of existing system

C = Present annual fuel cost

**Example:** How much would you save by changing from an old oil furnace to a new oil furnace with a high-static burner at 85% efficiency, if your present annual fuel cost is \$1,205?

The seasonal efficiency of the new furnace with a high-static burner is taken to be 85%, and the present oil furnace efficiency is 60%. Hence, A = 85%, B = 60%, (these numbers represent an average of the efficiency ranges given in Table 1) and C = \$1,205.

$$\text{Annual \$ savings} = \frac{85 - 60}{85} \times 1205 = \$354$$

Thus, you would save \$354 per year with this new oil furnace.

TABLE 1

## Typical Heating System Efficiencies and Energy Savings

Energy Source	Technology	Seasonal Efficiency (AFUE) %	Energy Savings % of Base*
<b>Oil</b>	Cast-iron head burner (old furnace)	60	Base
	Flame-retention head replacement burner	70–78	14–23
	High-static replacement burner	74–82	19–27
	New standard model	78–86	23–30
	Mid-efficiency furnace	83–89	28–33
	Integrated space/tap water (mid-efficiency)	83–89	28–33 space 40–44 water
<b>Natural Gas</b>	Conventional	60	Base
	Vent damper with non-continuous pilot light	62–67	3–10
	Mid-efficiency	78–84	23–28
	High-efficiency condensing furnace	89–97	33–38
	Integrated space/tap water (condensing)	89–96	33–38 space 44–48 water
<b>Electricity</b>	Electric baseboards	100	
	Electric furnace or boiler	100	
	Air-source heat pump	1.7 COP**	
	Earth-energy system (ground-source heat pump)	2.6 COP**	
<b>Propane</b>	Conventional	62	Base
	Vent damper with non-continuous pilot light	64–69	3–10
	Mid-efficiency	79–85	21–27
	Condensing	87–94	29–34
<b>Wood</b>	Central furnace	45–55	
	Conventional stove (properly located)	55–70	
	“High-tech” stove*** (properly located)	70–80	
	Advanced combustion fireplace	50–70	
	Pellet stove	55–80	

\* “Base” represents the energy consumed by a standard furnace.

\*\* COP = Coefficient of performance, a measure of the heat delivered by a heat pump over the heating season per unit of electricity consumed.

\*\*\* CSA B415 or EPA Phase II tested.

## Heating Costs with Different Energy Sources

You may be interested in calculating the cost of heating with oil and even comparing this amount to the costs of heating with other energy sources such as electricity, natural gas, propane or wood. If this is the case, you can use the following procedure. You need to find out the cost of the energy sources you wish to compare and the types of heating technologies that you might wish to use.

### Step 1: Determine the Price of Energy Sources in Your Area

Call your local oil, gas and electricity suppliers to find out the cost of energy sources in your area. This should be the total cost delivered to your home, and it should include any basic cost that some suppliers might charge, along with necessary rentals, such as a propane tank. Be sure to get the prices for the energy sources in the same units as shown in Table 2. Write the costs in the spaces provided. If your local natural gas price is given in gigajoules (GJ), you can convert it to cubic metres (m<sup>3</sup>) by multiplying the price per GJ by 0.0375. For example, \$5.17/GJ  $\times$  0.0375 = \$0.19/m<sup>3</sup>.

**TABLE 2**  
**Energy Content and Local Price of Various Energy Sources**

Energy Source	Energy Content		Local Price
	<i>Metric</i>	<i>Imperial</i>	
Oil	38.2 MJ/L	140 000 Btu/gal. (U.S.)	\$0. _____ /L
Electricity	3.6 MJ/kWh	3413 Btu/kWh	\$0. _____ /kWh
Natural Gas	37.5 MJ/m <sup>3</sup>	1007 Btu/cu. ft.	\$0. _____ /m <sup>3</sup>
Propane	25.3 MJ/L	92 700 Btu/gal. (U.S.)	\$0. _____ /L
Hardwood*	30 600 MJ/cord	28 000 000 Btu/cord	\$ _____ /cord
Softwood*	18 700 MJ/cord	17 000 000 Btu/cord	\$ _____ /cord
Wood Pellets	19 800 MJ/tonne	20 000 000 Btu/ton	\$ _____ /tonne

*Conversion 1000 MJ = 1 GJ*

\* *The figures provided for wood are for a "full" cord, measuring 1.2 m x 1.2 m x 2.4 m (4 ft. x 4 ft. x 8 ft.).*

## Step 2: Select the Type of Heating Appliance

Choose the type of equipment you want to compare from the list of appliance types in Table 1 on page 39. Note the efficiency figures in the column titled “Seasonal Efficiency.” By using these figures, you can calculate the savings you can achieve by upgrading an older system to a newer, more energy-efficient one or by choosing higher efficiency appliances with alternative energy sources.

## Step 3: Determine Your Home’s Annual Heating Load

If you know your heating bill and the unit cost of your energy source, you can determine your Annual Heating Load in gigajoules from the following equation.

$$\text{Annual Heating Load} = \frac{\text{Heating Bill}}{100\,000} \times \frac{\text{Seasonal Efficiency}}{\text{Energy Cost/Unit}} \times \text{Energy Content}$$

For example, you have an oil bill of \$1,220, an oil cost of \$0.329/litre and an old conventional oil furnace and burner (seasonal efficiency of 60% from Table 1).

$$\text{Annual Heating Load} = \left( \frac{1220}{100\,000} \right) \times \left( \frac{60}{0.329} \right) \times 38.2 = 85 \text{ GJ}$$

If your bill also includes tap water heating from the same energy source, you can still calculate your annual heating load, but it will require a little more care and calculation to separate out only your heating portion.

If you can’t get your heating bill, you can estimate your annual heating load in GJ from Table 3 (page 43) by selecting the house type and location that is closest to your own.

## Step 4: Use the Formula

The annual heating cost is calculated as follows:

$$\frac{\text{Energy Cost/Unit}}{\text{Energy Content}} \times \frac{\text{Annual Heating Load}}{\text{Seasonal Efficiency}} \times 100\,000 = \text{Heating Cost (\$)}$$

- Enter the cost per unit of energy and divide it by the energy content of the energy source; both numbers come from Table 2 (page 40).
- Select the annual heating load for your type of housing and location from Table 3 (page 43); divide it by the seasonal efficiency of the proposed heating system from Table 1 (page 39).
- Multiply the results of these two calculations, then multiply that result by 100 000.

The result should give you an *approximate* heating cost for your house. If you know your actual annual heating costs, as well as the type of heating system you have, you can modify the heating load originally taken from Table 3 to suit your specific house.

**Sample calculation:** You have a new semi-detached home in Fort McMurray and you would like to find out what the annual heating cost would be with a mid-efficiency oil furnace at 83% efficiency. To use the above formula, we can define the cost of oil as \$0.30/L, the house heating load as 80 (Table 3) and the energy content as 38.2 (Table 2).

Annual cost of oil heating:

$$\frac{\$0.30}{38.2} \times \frac{80}{83} \times 100\,000 = \$757$$

If you would like to compare this heating cost with those of other types of heating systems or energy sources, replace the numbers in the formula with the appropriate ones for your comparison using Tables 1 and 2 (pages 39 and 40).

TABLE 3

## Typical Annual Heating Loads in Gigajoules (GJ) for Various Housing Types in Canadian Cities

City	Old Detached	New Detached	New Semi-Detached	Townhouse
Victoria	85	60	45	30
Prince George	150	110	80	60
Calgary	120	90	65	50
Edmonton	130	95	70	55
Fort McMurray/ Prince Albert	140	105	80	60
Regina/Saskatoon/ Winnipeg	130	90	70	50
Whitehorse	155	115	85	60
Yellowknife	195	145	110	80
Thunder Bay	130	95	70	55
Sudbury	120	90	65	50
Ottawa	110	75	55	40
Toronto	95	65	45	35
Windsor	80	55	40	30
Montréal	110	80	60	45
Québec	115	85	65	50
Chicoutimi	125	90	70	55
Saint John	105	75	60	45
Edmundston	120	90	65	50
Charlottetown	110	80	60	45
Halifax	100	75	55	40
St. John's	120	85	60	45

**Note:** "New" means houses built in 1990 or later, and "old" means houses built before 1990. Due to construction practices, "weatherizing" and re-insulating (which can be different from house to house), these figures are meant to be used only as general guidelines; they should not substitute for an accurate heating requirement determination, as discussed in Chapter 5.

**Assumptions:**

Old detached – approximately 186 m<sup>2</sup> (2000 sq. ft.)

New detached – approximately 186 m<sup>2</sup> (2000 sq. ft.)

New semi-detached – approximately 139 m<sup>2</sup> (sq. ft.)

Townhouse – inside unit, approximately 93 m<sup>2</sup> (1000 sq. ft.)

## 5. THE MECHANICS OF BUYING, INSTALLING OR UPGRADING A SYSTEM

### Buying an Oil Heating System

You cannot shop for a furnace the same way you shop for a camera or a pair of shoes. There are no “furnace stores” where the different makes and models may be examined, compared and priced. To get first-hand information on the different makes and models available, you will have to contact a number of heating firms. Ask them for the manufacturers’ illustrated sales literature on the furnaces they sell and install. You should also contact your oil supplier or a local contractor for assistance and information. If you have decided on a particular type of furnace, read the literature carefully to find out if it describes the features you are looking for – such as a high-static flame-retention head burner and a delayed-action solenoid valve, etc. Look for its efficiency rating. This should be the seasonal (AFUE) rating, not just the steady-state efficiency. Make sure you distinguish between the two types of ratings. Compare it with Table 1 on page 39.

As previously mentioned, even the best oil furnaces do not run at their maximum efficiency if they are oversized and can make your home uncomfortable. A heating contractor cannot determine the size of furnace you need just by walking through your house. Do not buy a new furnace the same size as your present one; it may be as much as three times too large.

The contractor will have to calculate the heating requirements of your house using either the fuel consumption of your present furnace over a known winter period (together with the nozzle size, the steady-state efficiency, the degree-days between oil deliveries, the amount of oil consumed over that period, and the design temperature for your region) or by making a thorough measurement and examination of your house to determine size, insulation levels and degree of tightness of the house envelope. If the contractor does not show any interest in any of the above factors, then his or her calculation of the correct size for your new furnace will be simply a “guesstimate.”

To make sure proper furnace sizing is determined, the quotation and contract should include a statement like this one: **“The furnace size will be determined by a heat loss calculation using the formulas published by the Canadian Oil Heat Association; the Heating, Refrigerating and Air Conditioning Institute of Canada; the Canadian Standards Association; Natural Resources Canada; or other recognized organization. A copy of these calculations will be given to the homeowner.”**

It is important to hire a contractor who will install your equipment properly to ensure that it will operate efficiently. Check with your local fuel dealer or provincial/territorial heating fuel regulatory office to find out how to get in touch with a fully qualified, registered or licensed contractor. If your neighbours have had similar work done recently, ask them how satisfied they were with their contractors. If you are buying a relatively new type of furnace design, try to get the names of other homeowners who have had such equipment installed, and find out what they have to say about the appliance’s performance and the work of the installer.

Before you decide what to buy, obtain firm, written bids from several companies on a) the cost of upgrading your existing equipment, and b) the cost of buying and installing a complete new unit, along with any other fittings and adjustments required, including changes to any ductwork or piping and a final balancing of the heat supply to the house. With these figures and a reasonable estimate of the probable annual fuel savings determined from Table 1 on page 39, you will be able to determine how long it will take to recover the cost. This is not the only factor to consider, of course, but it is certainly one of the most important.

Remember that a building permit may be required for this type of work, and the contract should state whether the installer or the homeowner is responsible for obtaining it.

## **CHECKLIST FOR HAVING AN OIL HEATING SYSTEM INSTALLED**

**You should get several estimates on the work to be done.** When you are comparing these estimates, cost will be an important factor, but there are other elements to

consider. Some contractors are better at explaining what has to be done. Some may use higher quality components, and others may schedule the work at your convenience.

Estimates should include the following items:

- The total cost of **all** necessary work.
- An itemized list of **all** material and labour costs included in the bid: alteration or improvement of existing heat distribution ducts; installation of furnace and oil supply piping and ductwork; installation of water heater and vent (where applicable); installation of chimney liner and any attendant masonry work; and additional equipment such as humidifiers, air cleaners, or air conditioners.
- A statement describing how much of any existing equipment will be used in the new system.
- A rough diagram showing the layout of ductwork or water pipes and the location of supply piping and heating equipment.
- A statement that clearly defines who is responsible for:
  - all necessary permits and payment of related fees
  - on-site inspections, as required
  - scheduling of all other required work
  - removal of any existing equipment that will not be used with the new system
  - all related costs, such as subcontracts with tradespeople
- A clear estimate of when the work will be completed.
- A warranty for materials and labour.
- A schedule and method of payment.

Ask contractors for the names of homeowners for whom they have done similar work. The Better Business Bureau will know if the contractor is a member and whether any recent complaints have been filed against him or her. Your local Chamber of Commerce or Board of Trade may also be able to help.

Some dealers will also offer rental of heating equipment or lease-to-purchase plans. You may find it advantageous to participate in one of these plans rather than purchasing the equipment outright.

Do not hesitate to ask the contractor for a clear explanation of any aspect of the work before, during or after the installation of your heating system.

## **BILLING**

Billing for oil is handled in different ways, with two of the most common methods being equal billing and standard billing.

**Equal billing:** Your oil bill is paid in regular, equal installments, based on an estimate of your annual total consumption. Periodic adjustments are made to balance your monthly charge against your actual yearly household consumption.

**Standard billing:** The oil bills are paid on an as-delivered basis for oil consumed during that period.

## **Carbon Monoxide Detectors**

Because modern houses are more airtight and have more powerful air-exhausting systems, there is a greater chance that combustion products – containing deadly carbon monoxide gas – will linger inside your house and build up to potentially dangerous levels. A certified carbon monoxide detector located close to fuel-fired appliances (such as furnaces, fireplaces, space heaters, wood stoves, and gas or propane refrigerators) will signal a potentially dangerous situation that must be corrected immediately.

Symptoms of low-level carbon monoxide poisoning are similar to those of the flu – headaches, lethargy and nausea. If your carbon monoxide detector goes off and you have these symptoms, you should seek medical attention immediately.

If you have a conventional wood-burning fireplace, which can often leak carbon monoxide, and you plan to use it fairly often, it would be particularly wise to install a carbon monoxide detector.

## 6. MAINTENANCE

### Contractor Maintenance

The best way to keep heating equipment operating at peak efficiency is with a regular program of expert cleaning, servicing and burner tune-up. This must be done at least once a year, preferably well before the heating season arrives, and it must be done properly. It is not a half-hour job. Furnace manufacturers and the instructors who train servicepersons agree that **a proper cleaning and tune-up cannot be done in less than one-and-a-half hours, but often, it takes longer. A boiler may take two-and-a-half hours to clean and service thoroughly.**

Here are the tasks that a *serviceperson* should perform at every annual cleaning and checkup:

- Inspect the inside and outside of the chimney.
- Clean the furnace flue pipe, barometric damper and chimney base.
- Check the condition of the furnace heat exchanger.
- Use brushes and a vacuum cleaner to remove soot buildup from the heat exchanger cavities inside the furnace. These are difficult to reach in many furnaces, and it takes patience and perseverance to do a good job.
- Clean the furnace fan thoroughly. (This step applies only to warm air systems.) Dirt buildup on the curved blades can reduce the amount of air that is moved, which decreases furnace efficiency. On a belt-driven fan, the motor should be oiled where possible and the belt tension checked. Every two or three years, the fan should be removed from the furnace for a thorough examination and cleaning.
- Clean or replace the air filter (forced-air systems only).
- Open the burner and clean and lubricate the motor and blower fan if required. If the nozzle is dirty, it should be replaced, not cleaned.
- Check the oil pressure in the burner and examine all fittings for leaks.

- Clean the oil filter bowl and replace the cartridge if necessary.
- Check the performance of the safety features, such as the high limit control and the cad cell flame sensor.

Next comes the equally important job of adjusting the furnace for maximum efficiency. This cannot be done by visual inspection alone; it requires four different measurements made through a pencil-sized hole in the flue pipe, close to the furnace. Do not worry about flue gases escaping through this hole. In a properly adjusted furnace, this will not happen.

After the furnace has been running for about 15 minutes to a steady flue temperature, a sample of the flue gases is tested for its smoke content and the draft pressure is checked. Then the final two measurements are taken to determine the steady-state efficiency of the furnace: the temperature and the carbon dioxide or oxygen content of the flue gases leaving the furnace.

**All four measurements are essential to the proper adjustment of an oil furnace for optimum combustion performance.**

You can tell whether your furnace has ever had such attention simply by looking for a pencil-sized hole in the flue pipe. If there is no hole, then the smoke level and draft pressure have never been tested, and the steady-state efficiency has never been checked. If this is the case, talk to your fuel oil supplier or serviceperson about it.

## **SERVICE PLANS**

You may find it helpful to buy an annual furnace service plan. This provides an annual inspection, cleaning and tune-up, and 24-hour emergency repairs. Some plans include parts and labour; others cover labour only, which means you must pay for all parts required. Some firms offer additional insurance for complete furnace replacement, if this is ever necessary. An inspection is required before the service contract is signed. Payment is usually made annually.

## **Owner Maintenance**

There are a number of maintenance tasks that you can do yourself to keep your system working well. But even if you do these properly and regularly, **you should still have your system serviced annually by an expert heating contractor.**

### **ROUTINE CHIMNEY CARE**

Other than the sidewall-venting models, which have special venting requirements, all oil-fired furnaces and boilers require a Type A chimney (a double-walled, insulated, prefabricated metal chimney with a stainless steel lining), a masonry chimney lined with a clay flue tile, or a certified stainless steel liner in a masonry chimney. Sizing of the flue liner should be in accordance with the new CSA Standard CAN/CSA-B139-M91, *Installation Code for Oil-Burning Equipment*.

Although an oil furnace chimney rarely, if ever, needs to be cleaned, it should be checked occasionally for any sign of deterioration. You can check this simply by inserting a mirror in the cleanout opening at the bottom of the chimney on a bright day. Look for broken or flaking flue liner or interior chimney damage, as well as for water running out of the cleanout door or around the bottom of the chimney behind the furnace. Then examine the outside of the chimney. Look for the appearance of a white, powdery efflorescence on the outside of the chimney, spalling or flaking of the bricks, crumbling mortar joints, and wet patches on inside walls behind the chimney.

Certain types of higher efficiency systems, however, have special needs that may require your attention. Check your owner's manual or discuss this with your installer or serviceperson.

### **DEALING WITH CONDENSATION IN THE CHIMNEY**

Since the low temperature of the chimney itself is the major cause of condensation inside it, the problem can be overcome by installing an insulated metal liner such as a Type L, double-walled, stainless steel liner, or a single-

walled stainless steel liner surrounded by insulation, as per ULC requirements. Check with your provincial/territorial fuel safety division to find out which method it approves.

**Remember, the use of a sealed, double-walled stainless steel flue pipe from the furnace to the chimney is a good way to keep flue gases at a high enough temperature to help prevent condensation in the chimney.**

### A FURNACE “PHYSICAL”

There is a simple way to keep your eye on the condition of your furnace or boiler and monitor how efficiently it is using fuel. As we have seen, the heat that is not distributed through your house goes up the chimney, so measuring the temperature of the flue gases leaving the furnace will give a fairly accurate indication of its performance.

For a conventional oil-fired furnace, manufactured during the past 30 years, the maximum allowable temperature for the flue gases leaving the furnace was 400°C (750°F). It is normally between 175°C (350°F) and 280°C (540°F) – the lower the better, of course. To measure this, you will need a special probe-type metal thermometer (Figure 10) that looks like a kitchen meat thermometer but reads much higher temperatures – to at least 400°C (750°F). You can get one from a heating supply company, or ask your hardware store to order one for you from their thermometer supplier.

**Figure 10** Flue pipe thermometer

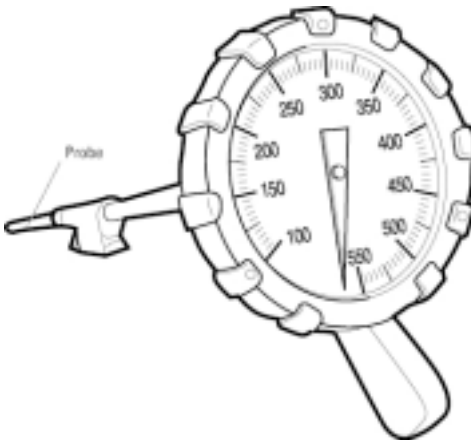

If the flue pipe does not have a hole, make one in the side of the furnace flue pipe about 40 cm (15 in.) from the furnace exit (but not right after a large bend) with a large nail or an electric drill. Insert the flue pipe thermometer probe, the end of which should be somewhere near the centre of the pipe. You can leave the thermometer in the hole permanently if you want – that way, you will not lose it. If you do this, remember to remove the thermometer and clean the probe end of any sooty deposit that may have built up before reinserting it to take a new reading. Turn the thermostat up to the maximum heat and let the furnace run for at least 15 minutes before taking a reading on the thermometer. **Don't forget to turn your thermostat back down after you have finished.** Check the temperature before and after the furnace is serviced to see if it has changed. Note any steady increase through the heating season; a rise of 25°C (77°F) represents a drop of about 3 percent in furnace efficiency and a corresponding increase in fuel consumption. In a forced-air heating system, this may mean only that the air filter is dirty and needs to be cleaned or replaced. If replacing the air filter does not reduce the flue temperature down to near where it was before, call your service company.

## **OWNER MAINTENANCE OF FORCED-AIR HEATING SYSTEMS**

### ***Cleaning or Changing the Air Filter***

**IMPORTANT!** Turn off the power to the furnace before opening the furnace access panel to check the filter or fan.

Few homeowners give the air filter in a furnace the attention it needs. It should be cleaned or replaced once a month. You can get permanent filters made of aluminum or plastic mesh that can be washed in a laundry tub, but these are not as fine as glass fibre filters and do not trap as much dirt.

If you have added an electrostatic air filter to your furnace, you do not need a standard filter as well. Remember that these electrostatic filters also need to be cleaned regularly; check your owner's manual for instructions.

## ***Fan Care***

Except for a superficial vacuuming, there is no maintenance that a homeowner can perform on a direct-drive furnace fan with an internal motor. On belt-driven fans, however, some motors have small oiling cups over the bearings on each end of the motor. These should be given a few drops of oil once or twice during the heating season and in the summer if you use your fan for ventilation or air conditioning. (Check your owner's manual to find out the type and quantity of oil to use.)

Check the tension of the fan belt by pressing it firmly in the centre with your thumb. You should be able to depress it by about 20 mm (3/4 in.) and no more than 25 mm (1 in.). The tension of the fan belt can be adjusted by loosening the bolts on the motor mount and moving it forward or backward. Make sure the fan and motor pulleys remain perfectly aligned. This job is best done by your furnace serviceperson.

## ***Distribution System Care or Maintenance***

Remove obstructions from ducts, warm air registers and cold air returns, so that air can move freely around the system. Use a special water-based duct mastic to seal any cracks in the duct joints, as described on page 21. At the same time, consider insulating as many of your warm air ducts as you can easily access.

## **OWNER MAINTENANCE OF HYDRONIC SYSTEMS**

Here are a few things you can do with a hot water heating system:

- Insulate hot water pipes.
- Once or twice a year, bleed air bubbles out of radiators so that they can fill with water.
- Vacuum the radiators.
- Check to see that the level of water in the expansion tank is below flood level.
- Oil the circulating pump (according to the manufacturer's instructions).

- Allow air to flow freely around radiators: make sure they are not covered by curtains or by ventilated wood panelling, and try to ensure that they are not directly behind furniture so that the heat generated can get into the rest of the room.

## 7. DOMESTIC WATER HEATERS

An increasing number of Canadian homes that are heated with oil also use oil for their domestic hot water supply. Domestic water heaters are the second-largest individual users of energy in most Canadian houses, after the space heating system. Depending upon the house type and the number and lifestyles of the inhabitants, hot water consumption may account for more than 20 percent of total annual energy consumption. One of the principal advantages of an oil-fired water heater is its quick recovery (due to higher combustion temperatures) – twice as fast as natural gas and five times as fast as electricity, based on the heat output of typical residential water heaters.

Free-standing oil-fired water heaters (see Figure 11 on page 55) now use burners with flame retention heads and other modifications that improve efficiency. They can be connected to an existing chimney or, in some cases, can be side-wall vented, if approved for it.

Most direct heat loss from water heaters is made up of losses by air and heat flow up the flue, both when the burner is firing and when it is not; by heat conducted through the tank walls and base; and by hot water convection losses through the hot and cold water feed pipes.

This chapter examines the options for improving the efficiency of the domestic hot water system by selecting and properly installing more efficient equipment. In the past, tap water was usually set to 60°C (140°F). Nowadays, the temperature is set lower to prevent scalding young children.

### Reducing Energy Losses

There are two basic types of oil-fired tap water heating systems: conventional water heaters that heat the water

directly in a tank and systems that heat the water in conjunction with another energy use, usually space heating. For the latter, it can be in the form of a “tankless coil” inside the boiler or a storage tank tied to the boiler through an efficient water-to-water heat exchanger.

The operating efficiency of a domestic hot water system can be improved significantly by designing the system carefully and selecting equipment that generates hot water more efficiently and reduces stack and standby losses. Modifying an existing system, including piping modifications, can also reduce some of the standby losses. Comparable to the AFUE of furnaces, the energy factor measures the seasonal performance of water heaters – the higher the number, the better the efficiency.

**Figure 11** Oil-fired hot water heater

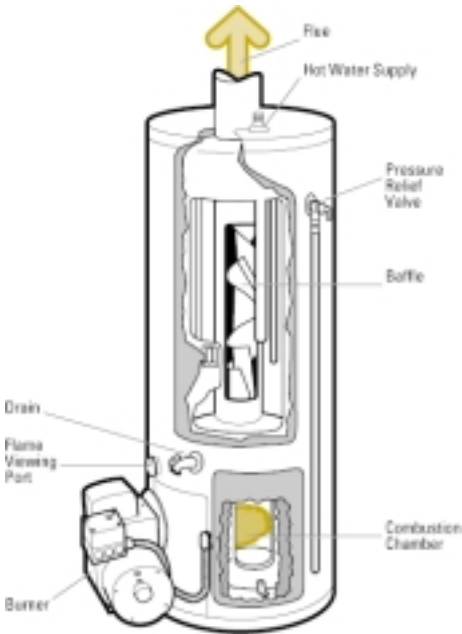

### ***Reducing Standby Losses***

The term “standby loss” refers to heat lost from the water in a domestic water heater and its distribution system to the surrounding air. It is a function of the temperature dif-

ference between the water and the surrounding air, the surface area of the tank, and the amount of insulation encasing the tank.

You should consider the following options to reduce stand-by losses:

- Install a heat trap above the water heater. A heat trap is a simple piping arrangement that prevents hot water from rising up in the pipes, thereby minimizing the potential for heat loss.
- Insulate hot water pipes to reduce the heat loss from the pipes themselves. Pipe insulation is available in a variety of materials and thicknesses, with easy application to most hot water pipes. Use insulation with an RSI (insulating value) of at least 0.35 (R-2) over as much of the pipe as you can easily access.

**It is extremely important not to insulate over any controls or obstruct the vent connections or combustion air openings. The insulation should not come in contact with the vent connector.**

- Place the water heater over a layer of rigid thermal insulation to reduce heat loss through the bottom of the tank. This is particularly applicable to electric water heaters and external storage tanks for integrated space and water heating systems.

**Before carrying out any of the steps listed above, check with your local installer or oil dealer to ensure that you will not compromise the safety or operation of the appliance.**

## **Integrated Space-Water Heating Systems**

Improvements to the building envelopes of homes have reduced the space heating load to the point where, in highly energy-efficient homes, it is sometimes difficult to justify the expense of a high efficiency furnace solely to satisfy the heating load. To take advantage of the efficiency potential of the new technologies, it may make sense to combine space heating with other functions, particularly water heating. Domestic hot water loads have remained fairly con-

stant and have even increased over time, making it a good idea to put more effort into improving the efficiency of the

**Figure 12** Schematic of an efficient oil-fired integrated space-water heating system

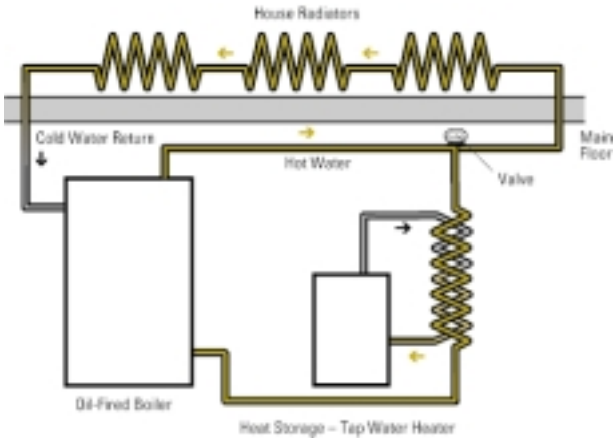

hot water generator. Therefore, it would be natural to combine space and water heating systems.

Combining the functions of space and water heating in one unit can lead to capital cost reductions for the equipment and, potentially, to increased efficiencies of operation. A schematic of such a system is shown in Figure 12.

The efficient integrated oil system couples a mid-efficiency, low-thermal mass boiler fired with a high-static burner to a well-insulated water storage tank, using an efficient water-to-water heat exchanger. When the house thermostat calls for heat, the boiler supplies heat to the house, either directly into a hydronic system or through a fancoil into a forced-air distribution system. When the house thermostat demand is satisfied, the boiler, instead of shutting off, continues to run, but dumps the heat across the heat exchanger into the tap water storage tank.

There are also oil-fired boilers on the market that provide a continuous supply of domestic hot water by circulating cold water through a finned copper coil immersed directly in the boiler water. This system is known as a **tankless coil**. The boiler must be kept hot even during the summer to give an adequate supply of tap water.

In the past, these systems were extremely inefficient and were usually grossly oversized for the house heat demands. Today, the efficiencies of some new tankless coil boilers have been improved by using a low-mass boiler with the coil and a well-insulated external storage tank, coming closer to the system described in the previous paragraph.

Another arrangement uses a conventional oil-fired hot water heater as the basic energy generator, with heated water being supplied to the house through a fan coil. Although this system has some advantages in terms of lower initial capital costs, its efficiency may not be as high as the systems described above.

Integrated systems are now being developed that offer promise for further improvement. If you are considering upgrading or replacing your heating system, you may want to think about installing an integrated space and water heating furnace or boiler. Your energy consumption for space and water heating may be higher if these services are provided by two separate units than if provided by a single integrated unit. In other words, integrated units may offer energy savings while still providing the same space heat and hot water. Mid-efficiency units are available and offer seasonal efficiencies of 80 to 95 percent for both space and hot water heating.

## **8. NEED MORE INFORMATION?**

### **Order Free Publications From the OEE**

The Office of Energy Efficiency (OEE) of Natural Resources Canada offers many publications that will help you understand home heating systems, home energy use and transportation efficiency. These publications explain what you can do to reduce your energy use and maintenance costs while increasing your comfort and helping to protect the environment.

### **ENERGUIDE FOR RENOVATING YOUR HOME**

*Keeping the Heat In* is a guide to all aspects of home insulation and draftproofing. Whether you plan to do it yourself

or hire a contractor, this 134-page book can help make it easier. Fact sheets are also available on air-leakage control, improving window energy efficiency and moisture problems. Consider getting the expert unbiased advice of an EnerGuide for Houses evaluation before you renovate. Our telephone operators can connect you with an advisor in your local area.

## **ENERGUIDE FOR HOME HEATING AND COOLING**

If you are interested in a particular energy source, the OEE has booklets on heating with electricity, gas, oil, heat pumps and wood. Other publications are available on heat recovery ventilators, wood fireplaces, gas fireplaces, air conditioning your home and comparing home heating systems.

## **ENERGUIDE FOR CHOOSING THE MOST ENERGY-EFFICIENT PRODUCTS**

When shopping for household appliances, office equipment, lighting products, and windows and doors, consult the OEE's series of Consumer's Guides. They'll help you know what to look for when it comes to energy efficiency.

The EnerGuide label, which is affixed to all new major electrical household appliances and room air conditioners, helps you compare the energy ratings of all models sold in Canada. EnerGuide ratings are also listed in the OEE's annual directories of major electrical household appliances and room air conditioners.

## **EVERY NEW HOUSE SHOULD BE THIS GOOD**

R-2000 homes are the best built, most comfortable homes in Canada, and they use up to 50 percent less energy than conventional dwellings. R-2000 homes feature state-of-the-art heating systems, high levels of insulation and whole-house ventilation systems that provide continuous fresh air to all rooms. Subject to quality assurance checks during the construction process, once completed, R-2000 homes are certified as being energy efficient.

## **BUYING, DRIVING AND MAINTAINING YOUR CAR**

For information on vehicle fuel consumption, look for the EnerGuide label that appears on every new automobile, van and light-duty truck for sale in Canada. It helps you compare different vehicles' city and highway fuel consumption ratings and estimated annual fuel costs. You can also check the OEE's *Fuel Consumption Guide*, produced annually, which provides the same information for all vehicles. The OEE's EnerGuide for Vehicles Awards also recognize the vehicles with the lowest fuel consumption in different categories.

Also available is the OEE's *Car Economy Calculator*, a fuel log that helps you calculate your fuel consumption and savings.

The OEE's *AutoSmart Guide* provides detailed fuel efficiency information and offers tips on purchasing, operating, and maintaining personal vehicles.

### **To receive any of these free publications, please write or call:**

Energy Publications  
Office of Energy Efficiency  
Natural Resources Canada  
c/o S.J.D.S.  
Ottawa ON K1G 6S3  
Tel: 1 800 387-2000 (toll-free)  
Facsimile: (819) 779-2833  
In the National Capital Region, call 995-2943.

*Please allow three weeks for delivery.*

**Publications can also be ordered or  
viewed on-line at the OEE's Energy  
Publications Virtual Library:  
[oe.e.nrcan.gc.ca/infosource](http://oe.e.nrcan.gc.ca/infosource).**

*Leading Canadians to Energy Efficiency at Home, at Work and on the Road*

The Office of Energy Efficiency of Natural Resources Canada strengthens and expands Canada's commitment to energy efficiency in order to help address the challenges of climate change.

Canada